

**Modular Cooking Range Line
 thermaline 85 - 2 Zone Full Surface
 Induction Top on Closed Base, 1 Side,
 Backsplash**

ITEM # _____

MODEL # _____

NAME # _____

SIS # _____

AIA # _____



588733 (MBJGBEOAA) Free-zone Induction on closed base, 2 zones, 1-side operated with backsplash

Short Form Specification

Item No. _____

Unit constructed according to DIN 18860_2 with 20 mm drop nose top and 70 mm recessed plinth. Internal frame for heavy duty sturdiness in stainless steel. 2 mm top in 1.4301 (AISI 304). Flat surface construction, easily cleanable. THERMODUL connection system enables seamless worktop when units are connected and avoids soil penetrating. Free zone multi-coil glass ceramic surface without dead spots can host up to 8 pots&pans. Minimum cookware diameter is 7 mm. UI design to control each coil independently, power (W) and temperature settings are possible. Filters easy accessible for cleaning by user. Overheat protection switches off the supply in case of overheating. IPX5 water resistance certification. Configuration: Freestanding on closed compartment, with backsplash.

Main Features

- The free zone induction offers the possibility to use multiple pots and pans, even small sizes (min diameter 7 cm), thanks to the multi-coil system design that makes all the surface active, ideal for à la carte menu.
- The smooth glass-ceramic surface features limited temperature increase and it can be quickly and easily cleaned, thus providing maximum hygiene.
- THERMODUL connection system creates a seamless work top when units are connected to each other thus avoiding soil penetrating vital components and facilitating the removal of units in case of replacement or service.
- 360° round stepless metal knobs, working clock and anticlock wise for quick parameters selection and adjustment.
- Each zone is controlled by a touch-sensitive keypad with 7 touch buttons, 4 displays and a round knob. Each zone consists in 4 coils, which can be individually controlled or bridged in 2, 3 or 4. Power (watts) or temperature (°C) can be selected. A function is also available to set and save 3 different configurations.
- Power setting from 25 to 2000 watt in 30 steps or temperature settings from 30 to 250° C in steps of 1°C.
- Electronic sensor, placed underneath the glass, below the coil center position, to precisely measure the temperature of the pan/pot bottom
- Overheat protection: the temperature sensor switches off the supply in case of overheating.
- Heating system automatically switches off when pots and pans are removed.
- Low heat dissipation to the kitchen.

Construction

- Unit constructed according to DIN 18860_2 with 20 mm drop nose top and 70 mm recessed plinth.
- Flat surface construction with minimal hidden areas to easily clean all surfaces
- Internal frame for heavy duty sturdiness in stainless steel.
- All major components may be easily accessed from the front, including the induction filters.
- 2 mm top in 1.4301 (AISI 304).
- Closed technical base, containing generators, ventilation system and filters.
- IPX5 water resistance certification.
- 6mm ceramic glass surface.

Sustainability



- This model is compliant with Swiss Energy Efficiency Ordinance (730.02).

Optional Accessories

- Scraper for cook tops PNC 910601
- Connecting rail kit for appliances with backsplash, 850mm PNC 912498
- Portioning shelf, 500mm width PNC 912523

APPROVAL: _____

• Portioning shelf, 500mm width	PNC 912553	<input type="checkbox"/>	• S02 Degreaser for ovens and SpeedDelight. Specific for cleaning the cooking chambers of GourmeXpress and SpeeDelight. Active up to a maximum of 50°C Complete with spray bottle Pack of 6 750ml bottles	PNC 0S2882	<input type="checkbox"/>
• Folding shelf, 300x850mm	PNC 912579	<input type="checkbox"/>	• S03 ALCOHOL BASE DETERGENT; 6 BOTTLES X 750ML; ADR&IMDG&IATA Limited Quantity	PNC 0S2883	<input type="checkbox"/>
• Folding shelf, 400x850mm	PNC 912580	<input type="checkbox"/>			
• Fixed side shelf, 200x850mm	PNC 912586	<input type="checkbox"/>	• S04 GLASSES & HARD SURFACES CLEANERS; 6 BOTTLES X 750ML	PNC 0S2884	<input type="checkbox"/>
• Fixed side shelf, 300x850mm	PNC 912587	<input type="checkbox"/>			
• Fixed side shelf, 400x850mm	PNC 912588	<input type="checkbox"/>	• S05 - MULTIPURPOSE DEGREASER; 6PCS X 750ML; ADR&IMDG Limited Quantity	PNC 0S3257	<input type="checkbox"/>
• Stainless steel front kicking strip, 500mm width	PNC 912631	<input type="checkbox"/>			
• Stainless steel side kicking strip left and right, wall mounted, 850mm width	PNC 912659	<input type="checkbox"/>			
• Stainless steel side kicking strip left and right, back-to-back, 1700mm width	PNC 912662	<input type="checkbox"/>			
• Stainless steel plinth, against wall, 500mm width	PNC 912879	<input type="checkbox"/>			
• Stainless steel side panel, 850x700mm, right side, against wall	PNC 913003	<input type="checkbox"/>			
• Stainless steel side panel, 850x700mm, left side, against wall	PNC 913004	<input type="checkbox"/>			
• Back panel, 500x700mm, for units with backsplash	PNC 913010	<input type="checkbox"/>			
• Endrail kit, flush-fitting, with backsplash, left	PNC 913115	<input type="checkbox"/>			
• Endrail kit, flush-fitting, with backsplash, right	PNC 913116	<input type="checkbox"/>			
• Endrail kit (12.5mm) for thermaline 85 units with backsplash, left	PNC 913206	<input type="checkbox"/>			
• Endrail kit (12.5mm) for thermaline 85 units with backsplash, right	PNC 913207	<input type="checkbox"/>			
• U-clamping rail for back-to-back installations with backsplash (to be ordered as S-code)	PNC 913226	<input type="checkbox"/>			
• Insert profile, d=850mm	PNC 913231	<input type="checkbox"/>			
• Side reinforced panel only in combination with side shelf, for against the wall installations, right	PNC 913261	<input type="checkbox"/>			
• Side reinforced panel only in combination with side shelf, for against the wall installations, left	PNC 913262	<input type="checkbox"/>			
• Stainless steel dividing panel, 850x700mm, (it should only be used between Electrolux Professional thermaline Modular 85 and thermaline C85)	PNC 913670	<input type="checkbox"/>			
• Stainless steel side panel, 850x700mm, flush-fitting (it should only be used against the wall, against a niche and in between Electrolux Professional thermaline and ProThermetic appliances and external appliances - provided that these have at least the same dimensions)	PNC 913686	<input type="checkbox"/>			
• Peak management system for Free-zone Induction, half module (8 coils)	PNC 921026	<input type="checkbox"/>			

Recommended Detergents

• C41 HI-TEMP RAPID DEGREASER, 1 pack of six 1 lt. bottles (trigger incl.)	PNC 0S2292	<input type="checkbox"/>
• S01 STAINLESS STEEL SURFACE POLISHER; 6 BOTTLES X 750ML C/T	PNC 0S2881	<input type="checkbox"/>

Front

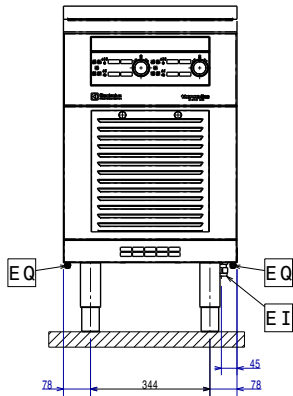

Side

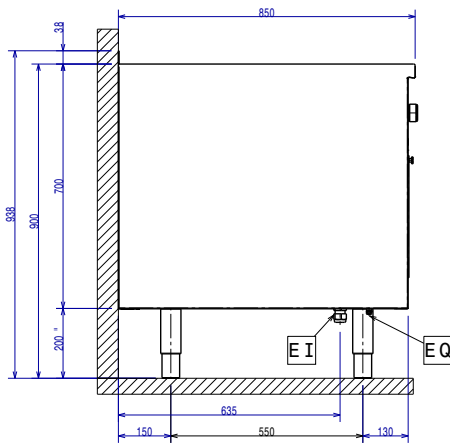

EI = Electrical inlet (power)
 EQ = Equipotential screw

Top

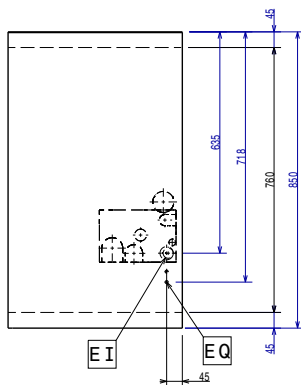
Electric

Supply voltage: 400 V/3N ph/50/60 Hz
 Total Watts: 16 kW

Key Information:

External dimensions, Width: 500 mm
 External dimensions, Depth: 850 mm
 External dimensions, Height: 700 mm
 Net weight: 50 kg
 Configuration: On Base;One-Side Operated
 Front Plates Power: 8 - 0 kW
 Back Plates Power: 8 - kW
 Front Plates dimensions: 320x320
 Back Plates dimensions: 320x320

Sustainability

Current consumption: 21.5 Amps